

## DOOR GRILLE

INVERTED "V" BLADES ON 1/2" CENTERS  
NO-VISION DESIGN

MINIMUM SIZE: 6" WIDTH x 4" HEIGHT

MAXIMUM SIZE: 96" WIDTH x 96" HEIGHT

EXTRUDED ALUMINUM; 6063-T5

FINISH - SA (CLEAR ANODIZE)

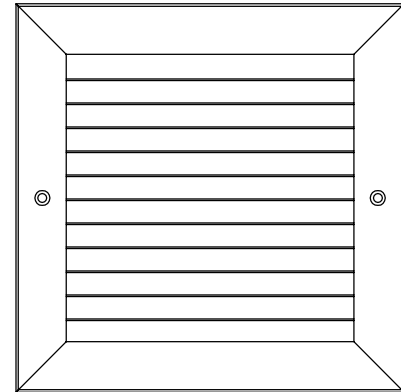

FACE VIEW

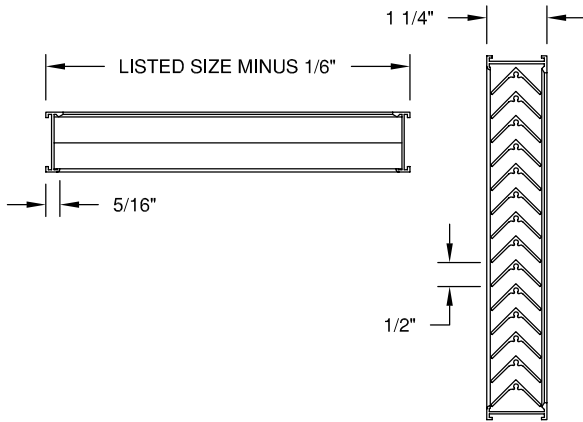

MODEL - DGC - FLANGLASS FRAME

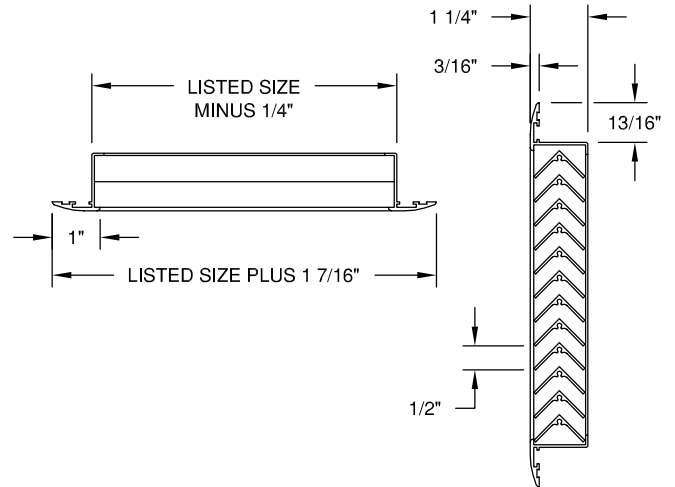

MODEL - DG1 - SINGLE FLANGE FRAME

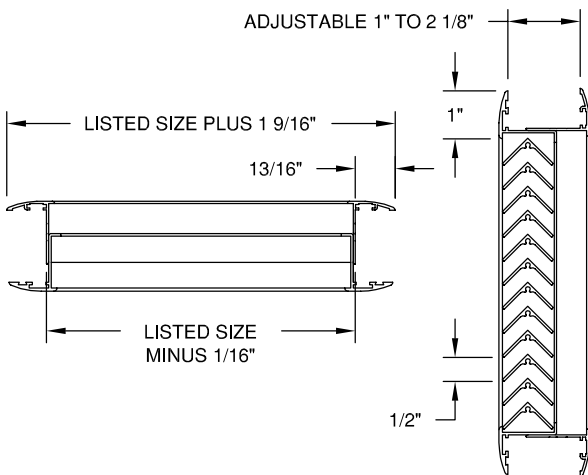

MODEL - DG2 - AUXILIARY FRAME

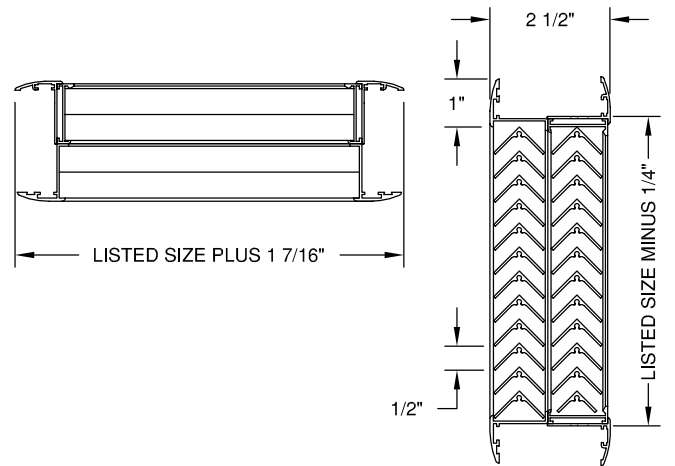

MODEL - DG2LR

DWG NO.

02HV058C

JOB NAME: \_\_\_\_\_

ENGINEER: \_\_\_\_\_

DATE:

10/28/02

LOCATION: \_\_\_\_\_

CONTRACTOR: \_\_\_\_\_

ARCHITECT: \_\_\_\_\_

FINISH: \_\_\_\_\_